



Backer Rod Mfg. Inc.

www.backerrod.com

Customer Service (800) 595 2950



UL System No. HW-S-0070

November 19, 2008

Assembly Rating – 4 Hr

Joint Width – 2 In. (51 mm) Maximum

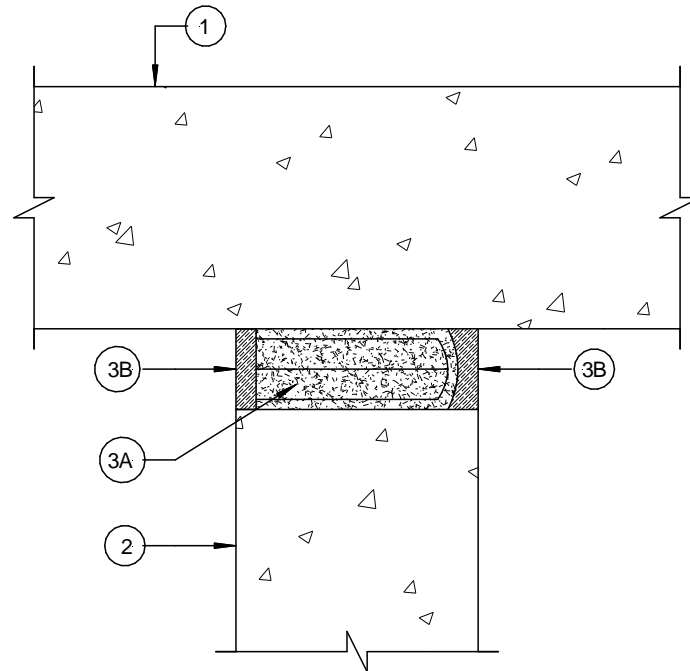

1. **Floor Assembly** – Min 5-3/4 in. (146 mm) thick steel-reinforced lightweight or normal weight (100 – 150 pcf or 1600-2400 kg/m³) structural concrete.
2. **Wall Assembly** – Min 6 in. (152 mm) thick reinforced lightweight or normal weight (100 – 150 pcf or 1600-2400 kg/m³) structural concrete. Wall may also be constructed of any UL **Classified Concrete Blocks***.

See **Concrete Blocks (CATZ)** category in the Fire Resistance Directory for names of manufacturers

3. **Joint System** – Max separation between bottom of floor and top of wall is 2 in. (51 mm). The joint system shall consist of the following:
 - A. **Forming Material*** - Min 12 in. (305 mm) width of forming material, folded in half and compressed min 27 percent into opening as a permanent form. Forming Material to be recessed from each surface of wall to accommodate the required thickness of fill material.
BACKER ROD MFG. INC. – ULTRA BLOCK®
 - B. **Fill, Void or Cavity Material*** - Min 1/2 in. (13 mm) thickness of fill material applied within the joint, flush with each surface of wall.
MOMENTIVE PERFORMANCE MATERIALS – PENSIL 300 SEALANT
SPECIFIED TECHNOLOGIES INC – PENSIL 300 SEALANT or SPECSEAL SERIES SIL300 SEALANT

*Bearing the UL Classification Mark

This material was extracted and drawn by Backer Rod Mfg. Inc. from the 2009 UL Fire Resistance Directory
Copyright © 2009 Underwriters Laboratories Inc.®